



## Model A70-P Barometric Pressure Transmitter

Document 1017, Version K



A70-P-T Track Mounted

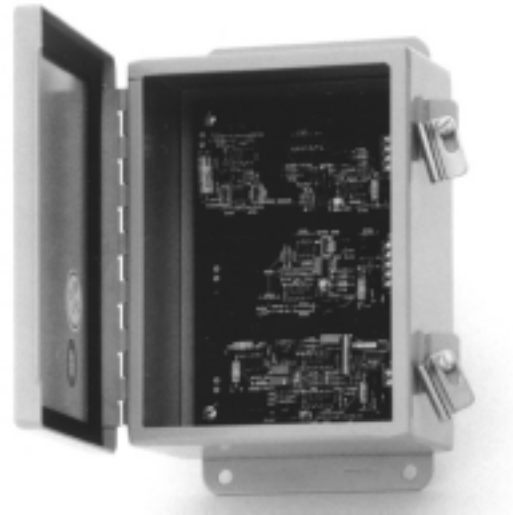

A70-SDPL-N12 in NEMA 12 Box

The barometric pressure is sensed by an integrated silicon absolute pressure sensor with internal temperature compensation. The sensor is mounted to the signal conditioner board. A 3/16 inch diameter tube may be attached to the sensor to provide remote pressure sensing. The output of the sensor is scaled to provide the desired output signal.

Systems are available with outputs of 0-1 mA, 0-1 V or 4-20 mA. All systems may be powered from either 120 VAC, 230 VAC or 12 - 24 VDC.

The instruments are available in a variety of packages including steel JIC boxes meeting NEMA 12 standards, weatherproof fiberglass enclosures

meeting NEMA 4X, IP66 and IEC 529 standards and track mounted versions. NEMA 12 enclosures provide protection from dust for indoor applications. NEMA 4X enclosures may be used indoors or outdoors. They provide protection from corrosion, wind blown dust and rain and are undamaged by ice. Track mounted versions are intended for mounting inside an enclosure provided by the user. Where required, electrical connection to the sensor is via terminal block. A barrier strip is provided for connection to operating power.

Each system is provided with a detailed instruction manual.



WWW.COMPTUS.COM Phone: 603 726-7500 Fax: 603 726-7502

## Specifications

Range: / E 27 - 31 inches of mercury  
/M 900 - 1100 mili Bar

Worse case error:  $\pm 0.05$  inches Hg,  $\pm 2$  mili Bar

Size: Track Mount 1.75 inches W X 5.0 inches L X 1 inches H  
NEMA 12 6 inches W X 8 inches H X 4 inches D  
NEMA 4X 6 inches W X 8 inches H X 4 inches D

Weight : Track Mount 1 lbs  
NEMA 12 6 lbs  
NEMA 4XFG 4 lbs  
NEMA 4XSS 6 lbs

Operating Temperature : Electronics 0/60° C

Connectors : Barrier strips to accept AWG #12 or smaller wire

Options : Expanded Ranges

Accessories : A96 Lightning protectors  
A70-LPDD Digital Display  
A10 Mechanical Chart Recorders  
Data Chart - Electronic Chart Recorder  
A33 Data Logger / Controller

**A70-LPDD**  
**Loop Powered Digital Display**



**A70-LPDA**  
**Loop Powered Analog Display**



## DESCRIPTION

The A70-PL provides a 4-20 ma signal proportional to barometric pressure. The instrument utilizes a temperature compensated IC pressure transducer to measure the ambient pressure. The output from the pressure transducer modulates the transmitter's loop current. The instrument as supplied is calibrated to absolute pressure. The instrument may be adjusted to sea level pressure if desired by means of the offset adjustment.

The barometric air pressure sensor has a 3/16 inch diameter port. Flexible tubing may be attached to this port if it is desired to monitor air pressure at a remote location. Other ranges are available up to 100 psi absolute or + 100 psi gage.

The system may be packaged in a rugged steel box or as a circuit board with mounting track. The steel box has a NEMA 12 rating. Two 1/2" conduit hubs on the side walls provide electrical access to the unit. Top and bottom ears with two 1/4" holes each provide means for wall mounting. The track mounted version is suitable for installation inside an existing enclosure. The track is easily attached to a back plane with two screws.

### DataChart Electronic Chart Recorder



## INSTALLATION

Before proceeding verify that the maximum resistance of the current loop including the wiring and sensing element does not exceed the maximum given by Formula 1. If this resistance is exceeded the loop current will not attain full scale.

### Formula 1

Maximum Loop Resistance

R - Maximum Loop Resistance in Ohms

V - DC Excitation Voltage

$$R = (V - 10 \text{ Vdc}) \times 50$$

The resistance of various gages of copper wire is given in Table 1.

Table 1

Wire Gage AWG	Resistance in Ohms per foot
12	.0016
14	.0026
16	.0041
18	.0065
20	.0103
22	.0165
24	.0262

Figure 1

Graph of Maximum Loop Resistance

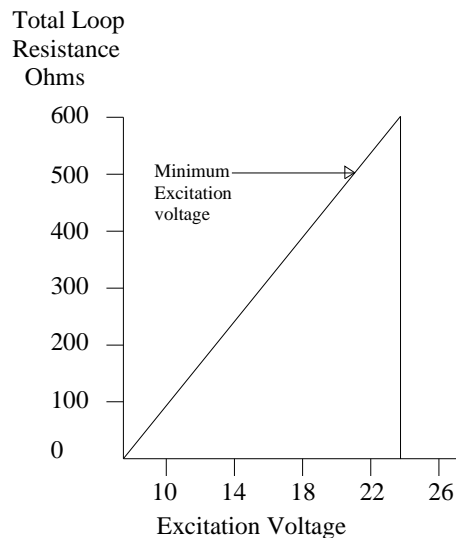

## Installation *Continued*

1. Select a suitable mounting location where the temperature can be maintained between 0 and 50 degrees C.
2. Mount the instrument to a wall or other suitable panel.
3. Connect the two wires from the current loop to the terminals on the barrier strip, taking care to observe polarity.
4. Apply power to the loop and allow the system to stabilize for 20 minutes or more while proceeding with Step 5.  
Note: Adjustment of the "GAIN" potentiometer is not initially required. If calibration is necessary after a year or more of service a suitable pressure reference will be required.
5. Determine local barometric pressure as referred to sea level. A nearby radio or television station weather report is generally suitable. Refer to Formula 2 and calculate the desired loop current.
6. Refer to Figure #3 and locate the "baro. offset" adjustment. Use this as a course adjustment. Turn the small screw on the top to set the loop current calculated in Step 5 to within  $\pm 0.5$  mA.
7. Locate the "ZERO" adjustment. Turn the small screw on top to obtain the final adjustment for the loop current calculated in Step 5  $\pm 0.02$  mA.

### Formula 2

Loop Current Given a Known Pressure

I- Loop current in ma

P- Barometric pressure in inches of mercury

$$I = (P \times 4) - 104 \text{ ma}$$

## Lightning Protection

The Transmitter electronics has integral metal oxide varistors for protection from lightning induced surges, electrostatic discharge and other atmospheric discharges. Wind blown aerosols such as sand and snow can generate electrostatic charges with consequences similar to lightning discharges. The A96 Series of gas tube surge arrestors can safely dissipate much higher energy discharges than the internal varistors.

A consequence of the rapid rise time of these electrostatic discharges is the inductance of the grounding system and interconnecting wiring is generally of more concern than resistance. Gas tube surge arrestors should be placed as close to the device they are intended to protect to minimize the effect of inductance in the wiring.

**A96-100P Surge Arrestor**

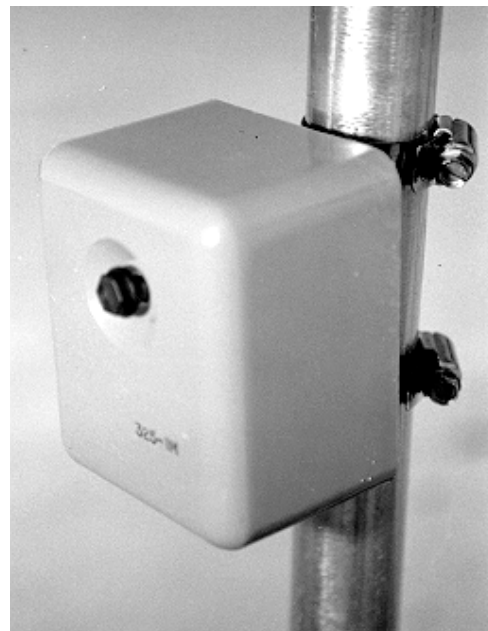

**Figure #2**  
**Connection Diagram**

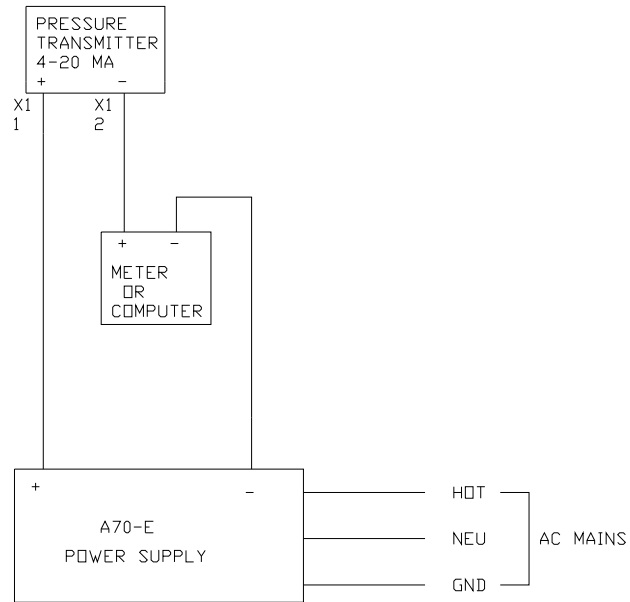

**Figure #3**  
**Component Layout**

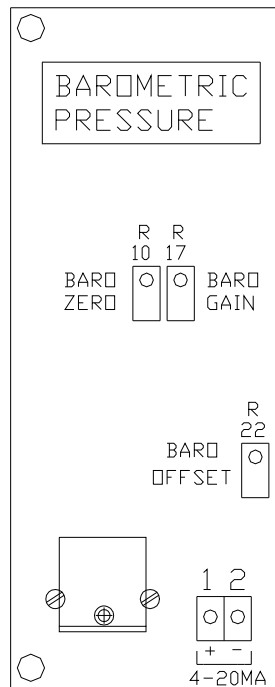

**Figure 4**  
**Multiple Transmitters with One Power Supply**

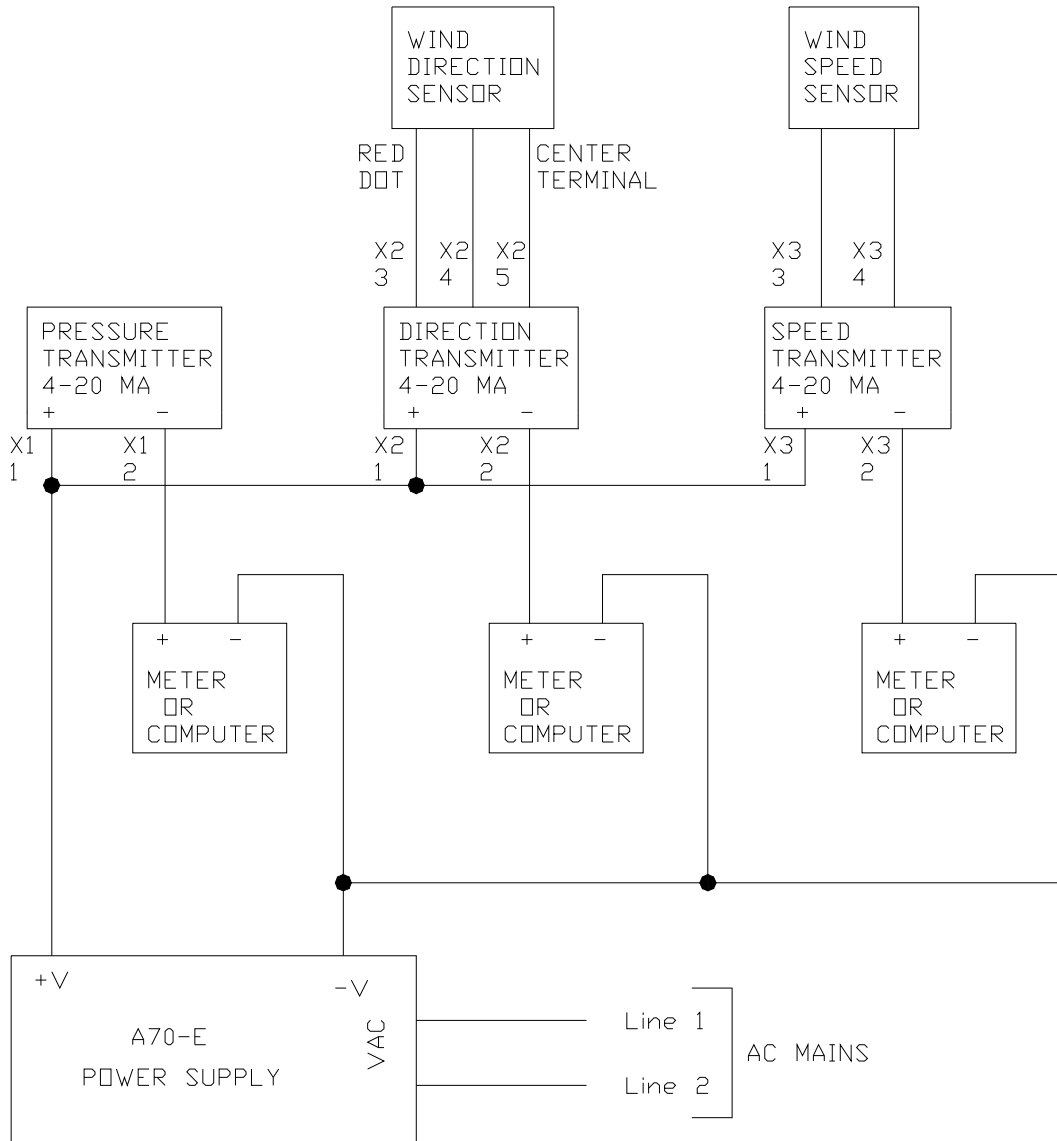

## OPERATION

Operation of the transmitter is fully automatic. A loop current in the range of 3-4 ma or 20-30 ma indicates a pressure outside the range of the instrument.

Refer to Formula 3 to determine barometric pressure given the loop current.

### Formula 3

Barometric Pressure Given a Known Loop Current

P - barometric pressure in inches of mercury  
I - loop current in ma  
 $P = (I + 104)/4$

### Formula 4

Barometric Pressure Given a Known Loop Current

P - barometric pressure in milli Bar  
I - loop current in ma  
 $P = (I \times 12.5) + 850$

**Figure 5**  
**Graph of Barometric Pressure Transfer**  
**Function for Range E**

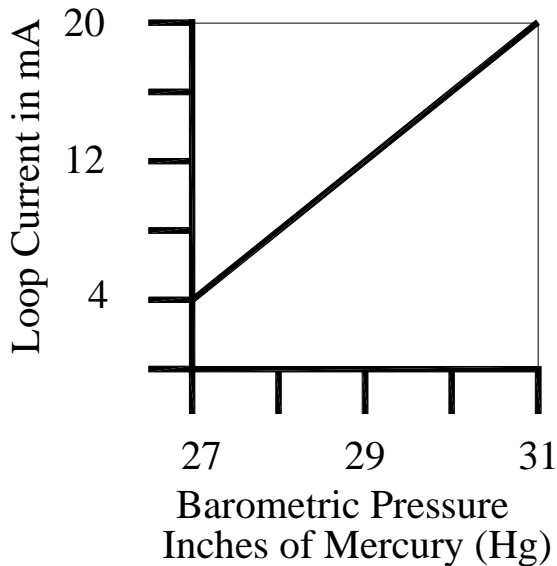

**Figure 6**  
**Graph of Barometric Pressure Transfer**  
**Function for Range M**

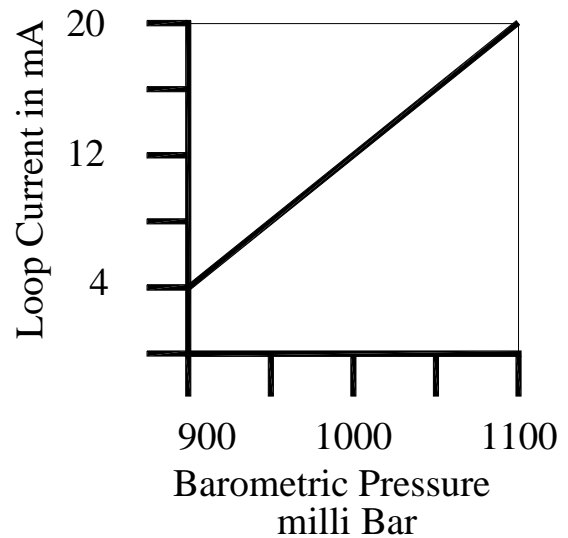

It is possible to monitor the loop current indirectly by measuring the voltage drop across a known resistance installed in series with the current loop.

**Formula 5**

Voltage Across Sensing Resistor

I Loop Current in Milliamperes  
R Resistance in Ohms V Voltage in Volts  
 $V = I \times R / 1000$

**Figure 7**  
**Graph of Voltage Vs Loop Current**  
**for 100 ohm Load**

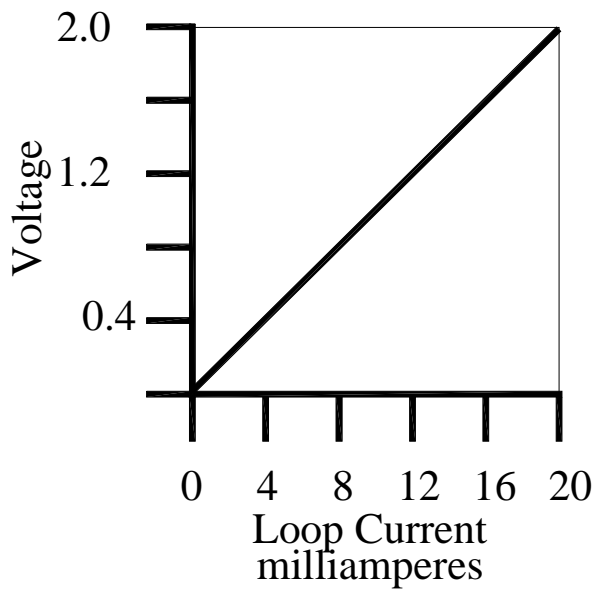

**A76-T10 Tripod Tower**





## TROUBLE SHOOTING

### *Philosophy*

Effective trouble shooting requires that problem locations be systematically eliminated until the problem is found.

There are four basic questions to answer when trouble shooting (Ref. #1):

1. Did it ever work right?
2. What are the symptoms that tell you it's not working right?
3. When did it start working badly or stop working?
4. What other symptoms showed up just before, just after, or at the same time as the failure?

It is best to write down any clues you may obtain. Be sure to write down anything unusual.

The response to question #3 should probably not be 3:04 P.M.. A useful response might be, "Just after an electrical storm." or, "Just after it fell off the shelf."

Double check all the simple solutions to the problem before searching for complex ones. If the problem occurs right after installation, it probably has a simple solution.

If an automobile engine cranks, but doesn't start, make sure there is fuel in the tank before replacing the engine. If the electronic equipment doesn't function, verify that it has power and is turned on.

Systems containing parts which can be quickly interchanged are easy to trouble shoot. Swap parts until the problem moves. The location has then been narrowed to the part that caused the problem to move.

Sometimes there are multiple problems. These reveal themselves in layers much like peeling an onion.

It often helps to explain the problem to another person, even if that person is not knowledgeable about the particular piece of equipment.

This does two things. First it requires you to organize the situation so it can be explained to another. Secondly, it may turn out that you are so familiar with the situation that you have overlooked the obvious. Another person unfamiliar with the equipment may be able to help.

If you are unable to solve the problem, put it aside until the next day. Some new thoughts will probably occur while working on another project.

### References

1. "Troubleshooting is More Effective with the Right Philosophy", Robert A. Pease, Electronic Design News, January 5, 1989.

### *Trouble Shooting Procedure*

Loop Current :0 mA

Failure Description :

Polarity reversed

Open circuit in cable

Power supply failure

Transmitter failure

Loop Current :Less than 3 ma

Failure Description :

Low power supply voltage

Loop resistance too high

Loop Current : Greater than 20 ma

Failure Description :

Ambient pressure above range Adjust

"Baro. Offset"

Transmitter failure

Loop Current :Does not reach 20 ma, otherwise operates properly

Failure Description :

Low power supply voltage

Loop resistance too high

## **MAINTENANCE**

No maintenance is required except to check calibration at yearly intervals. See recalibration section.

## **CALIBRATION**

### **Altitude Adjustment**

1. Apply power to the loop and allow the system to stabilize for 20 minutes or more.

Note: Adjustment of the “GAIN” potentiometer is not initially required. If calibration is necessary after a year or more of service a suitable pressure reference will be required.

2. Determine local barometric pressure as referred to sea level. A nearby radio or television station weather report is generally suitable. Refer to Formula 2 and calculate loop current.
3. Refer to Figure #3 and locate the “baro. offset” adjustment. Use this as a course adjustment. Turn the small screw on the top to set the loop current calculated in Step 2 to within  $\pm 0.5$  mA.
4. Locate the “ZERO” adjustment. Turn the small screw on top to obtain the final adjustment for the loop current calculated in Step 2  $\pm 0.02$  mA.

## **Recalibration**

### **BAROMETER**

The transmitter is calibrated when shipped from the factory. Recalibration requires special equipment and should only be attempted with guidance from the factory. A milliammeter & means of generating the reference pressures are required.

See Transmitter installation section for altitude adjustment.

See Figure 2. Connect the transmitter to a power supply. Allow the circuit to stabilize for 20 minutes or more for best accuracy.

#### **Calibration Range - E**

1. Apply a pressure of 27 inches of Hg to the pressure transducer using a tube with 3/16" id.
2. Monitor the output current and adjust the “baro. offset” potentiometer to produce 4.02 mA.
3. Apply a pressure of 30 inches of Hg and adjust the “baro. gain” potentiometer to produce a loop current of 15.98 - 16.02 mA
4. Repeat steps 1 - 3 until instrument is in calibration.

#### **Calibration Range - M**

1. Apply a pressure of 900 mBar to the pressure transducer using a tube with 3/16" id.
2. Monitor the barometer loop output current and adjust the “baro. offset” potentiometer to produce a loop current of 3.98 - 4.02 mA.
3. Apply a pressure of 1050 mBar and adjust the “baro. gain” potentiometer to produce a loop current of 15.98 - 16.02 mA
4. Repeat steps 1 - 3 until instrument is in calibration.

## LIMITED WARRANTY

COMPTUS Inc. extends this warranty to the original consumer only. Any product manufactured by Comptus is warranted against defect for a period of ONE YEAR beginning on the date of purchase by the consumer or two years beginning on the date of purchase from Comptus by the authorized dealer, whichever expires sooner.

TO OBTAIN WARRANTY SERVICE, the purchaser must contact Comptus and receive return authorization. Such correspondence should be addressed to: Comptus, 202 Tamarack Rd., Thornton, NH. 03285. All warranty service is performed at the factory. All incidental expenses, including shipment of products to Comptus by the purchaser, shall be the sole responsibility of the purchaser. WARRANTY SERVICE is at the sole discretion of Comptus and free of charge for parts and labor. Under the above terms, Comptus will repair or replace the defective component(s), provided that:

- a) the product has not been subjected to abuse, neglect, accident, alteration, improper installation or servicing, or used in violation of instructions furnished by Comptus;
- b) the product has not been repaired or altered by anyone except Comptus or its authorized service agencies;
- c) the serial number has not been defaced, removed, or otherwise changed;
- d) the damage has not been caused by acts of nature including windstorm and hail beyond those specified as within the range of operating conditions;
- e) the damage has not been caused by shipping.

**THIS WARRANTY IS IN PLACE OF ALL OBLIGATIONS OR LIABILITIES ON THE PART OF COMPTUS FOR DAMAGES. IT DOES NOT APPLY TO ANY COMPONENT OR EQUIPMENT RESOLD BY COMPTUS IN ITS ORIGINAL CONDITION AS RECEIVED BY COMPTUS FROM THE MANUFACTURER OR DISTRIBUTOR, AMONG THE DAMAGES EXCLUDED FROM THIS WARRANTY ARE ANY INCIDENTAL OR CONSEQUENTIAL DAMAGES ARISING OUT OF OR IN CONNECTION WITH THE PRODUCT IN ANY WAY. Any implied warranties are limited in duration to the duration of the written warranty. No representative or person is authorized to give any other warranty or assume for Comptus any other liability in connection with the sale of its products.**

THIS WARRANTY GIVES YOU SPECIFIC LEGAL RIGHTS, AND YOU MAY ALSO HAVE OTHER RIGHTS WHICH VARY FROM STATE TO STATE. SOME STATES DO NOT ALLOW THE EXCLUSION OR LIMITATION OF INCIDENTAL OR CONSEQUENTIAL DAMAGES OR LIMITATIONS ON HOW LONG AN IMPLIED WARRANTY LASTS, SO THE ABOVE LIMITATIONS AND/OR EXCLUSIONS MAY NOT APPLY TO YOU. This warranty complies with the Magnuson-Moss Consumer Warranty Act, and completely replaces any warranty printed on promotional material describing products of Comptus Inc.

## **HOW TO RETURN EQUIPMENT TO COMPTUS**

1. Contact the Comptus Service department with the model and serial number of the unit. Be prepared to provide the symptoms of the problem as many are solved without the need for returning the equipment. Have a person with firsthand experience of the trouble on hand to provide specific information.

2. Comptus will issue a Return Material Authorization Number (RMA#) if required. This will ensure the fastest response and least cost for all parties. Please reference this number in all correspondence. This number should be printed on the shipping container.

3. Include a description of the service desired with the returned equipment. If the equipment is being returned for repair, please include a description of the problem.

4. If the equipment is packaged in a plastic case, wrap it in aluminum foil, or other conductive material. This will protect it from static electricity, as well as prevent the packing material from jamming mechanical parts, such as switches. Otherwise, place the equipment in a plastic bag, again to prevent contamination by packing material.

Place the equipment in a suitable shipping container and fill with packing material. There should be at least one inch of packing material between the equipment and the shipping container on all sides.

5. Equipment will be returned C.O.D. to sender if any charges are incurred, unless other arrangements are made in advance.

### **SHIP THE EQUIPMENT TO:**

Comptus  
202 Tamarack Rd.  
Thornton NH 03285 U.S.A.  
Telephone: 603 726-7500  
Fax: 603 726-7502  
E-mail: service@comptus.com

**NOTE:** Please be sure to include the RMA Number, as described in Item 1, on the shipping container.



**WWW.COMPTUS.COM Phone: 603 726-7500 Fax: 603 726-7502**

	<b>Packing List</b>
Quantity	Description
1	Pressure Transmitter
1	Instruction Manual
1	Certificate of Calibration

**IMPORTANT:** Please check your order on receipt to be certain all listed accessories are included before discarding shipping container or packing material. All shortages must be reported within 10 days of receipt.



**WWW.COMPTUS.COM Phone: 603 726-7500 Fax: 603 726-7502**



**WWW.COMPTUS.COM Phone: 603 726-7500 Fax: 603 726-7502**